

Using Simulation Modeling for IT Cost Analysis

Timofei Popkov (tim@xjtek.com), Yuri Karpov (karpov@xjtek.com),
Maxim Garifullin (maxim@xjtek.com)

<http://www.xjtek.com/> | <http://www.xjlabs.com/>

St.Petersburg State Technical University,
Distributed Computing and Network Department
St.Petersburg, Russia

Abstract

In the old days, the price for IT services was formed in a pretty standardized way. Network services had an explicit usage price per Kbit/ sec. The range of provided IT services have been growing very fast and have reached new dimensions of complexity. From infrastructure pricing to web-enabled application availability and performance nowadays the old rules for defining service pricing is not applicable any more. Today it is difficult or sometime even impossible to associate the provided service levels with the cost related to the processes of operation, maintenance and the capital cost behind it. The old measures of dollars per Kbit/sec cannot be the right measure any more. For example setting the price for one transaction per second does not define at all what is needed to perform two transactions per second. What should be a penalty in the case of breaking SLAs? Where is the golden mean here? How can it be found?

In the paper we consider solving such kind of tasks by means of simulation. The simulation model can serve as a decision support tool for predicting (calculating) the price for a particular service, which is being provided. Using such models by service providers will ensure them with high probability of cost recovery and profit, competitiveness of prices, and encouragement of client behaviors that will enhance the services' efficiency. The implementation and usage costs of the models are low as soon as it can be done in easy way and without special knowledge in simulation.

Introduction

Any commercial company aims to be successfully in its market but there is one thing, which is more difficult to achieve: to be profitable. In the contemporary conditions of keen competition it is needed to count all aspects, which influence company efficiency in order to get ahead of competitors and get the results.

The motto of nowadays business is "Do more with less, and deal constant change- all with tighter budget constraints than ever" [4]. All that makes companies to put more attention to the following aspects:

- Manage costs. Company's products/service will have to be competitive and profitable on the market and as a result the costs of all business and industrial processes should be minimized but the quality level should not be decreased.
- Increase quality. Quality is one of the key parameters of any company. The organization of business, management and industrial processes are very important in archiving company goals.
- Mitigate risks. Business faces unrelenting pressure and it is impossible to get the results without well-conducted risk management.
- Improve agility. In order to be effective company has to immediately react on changes (e.g. market changes, new laws, new technologies etc.)

There are various ways to manage these aspects. There are a lot of software products, services, and solutions, which can help in achieving these goals but how a company can be

ensure that it will really drive to the results? How can company take a decision about actions that should be taken in order to get the results? How to answer the question like below:

- What is the current company efficiency?
- How can we improve company efficiency and what is needed for that?
- How can we minimize cost and increase quality?
- Is it needed at all to improve company efficiency and what is reasonable cost of improvements?
- Etc.

There is only one way to answer these questions – modeling. There are two types of modeling – analytical and simulation. In terms of being applied to company, analytical modeling is a set of equations described (mathematical representation) company's business processes, flows, and IT infrastructure. Usually it is impossible or very difficult to express analytically various dependencies, which describe company's processes, especially when we are talking about complex processes. Actually analytical modeling cannot accurately model complex environments. Simulation modeling is the ability to create a model of the entire customer environment complete with business process, flows, and IT infrastructure and then perform simulations of the interactions between all these components. Simulation modeling is effective for any company but uniquely capable for complex eBusiness environment.

In this paper we consider simulation modeling for estimating efficiency of an IT company and address questions introduced above. We mainly consider companies which core business is providing IT services but the approach we suggest can be also successfully applied for any other company.

Simulation Modeling of a Company

Company consists of a lot of processes - business, management and industrial process and depending on the goals of simulation one, few, some or all of these processes can be modeled. Usually company modeling include modeling the following basic components:

- Manufacturing processes. It includes modeling conveyer, technological processes, workers involved in the process etc.
- Logistics. It includes modeling and optimization warehouse, products delivery, supply chain etc.
- Sales department and Billing department. It includes modeling orders flow, invoices flow, payments flows etc.

There are some approaches, which allow modeling and simulation of these components. Through simulation, it is possible to estimate the impacts to overall company business process. Today, simulation allows interacting with all aspects of the logistics and manufacturing processes and evaluating the vision prior to implementation.

But modeling of the listed above components doesn't include modeling of one very important thing - company IT infrastructure. As soon as almost any company in the world employs IT technologies in its business and as a result depends on them, the organization and efficiency of IT infrastructure is one of the most important factors in company success, especially when we are talking about companies which core business is based on IT technologies (e.g. e-shops, service providers, online payment systems etc.). IT infrastructure plays an important role in optimization companies business processes and actually is "nervous system" of business that even provides in plenty of cases the opportunity of existence this or that management or industrial processes.

So, without modeling and simulation of company IT infrastructure it is impossible to estimate such important parameters like return on IT infrastructure, impacts of changes in IT infrastructure, efficiency of IT infrastructure and so on. Besides in order to archive overall company agility IT infrastructure should react fast on any changes in business processes and simulation modeling helps a lot in achieving this goal allowing estimating efficiency of IT infrastructure, trying various scenarios, estimating the impact of changes in business processes and as a result reduce reaction time on the changes, estimate range of changes and level of efforts to introduce and(or) support them. All that is especially important when a company, which provides IT services, should be estimated. Actually there are no simulation tools, which allow estimating efficiency of an IT company including its IT infrastructure. There are only few tools for evaluating network and servers' performance and that is all.

Simulation Modeling of Company IT Infrastructure

Before describing in detail the company's IT infrastructure modeling we would like to explain more precisely what company efficiency mean and how it is expressed. In fact it is possible to choose various metrics of company efficiency, e.g. for IT company it can be network and servers' performance, for manufacturing company it can be products per days and so on, but there is one most important metric applicable for any commercial company – it is money. Each operation inside company cost something and as a result affects company revenue. In IT company model example that is described in the following section the company balance is calculated and provides summarizing view of the company efficiency.

If there are few approaches how to estimate efficiency of manufacturing processes or logistics it is still unclear how to estimate efficiency of company IT infrastructure. Usually it is possible to find a simple operation that takes some time and cost some money (simple operation examples: conveyor screws a lid on a jar, sales man proceed an order etc), and than simulate them but it is impossible in the case of simulation IT infrastructure. As a simple operation in IT infrastructure transaction may be considered (Kbytes is an old metric and can't reflect all IT infrastructure parameters like e.g. servers' load) but what should be the cost of one(some) transactions? Cost depends on time of execution of one transaction but execution time depends on number of transactions, which are currently executed, and type of those transactions (transactions may have various types e.g mail transaction, web transaction, database transaction etc) an so on. So, as one can see the picture is rather complex and it is not clear how to simulate such systems. Our suggestion on modeling IT infrastructure is based on the following basic assumptions:

1. We can measure end-to-end transactions efficiency and use these measurements as input for simulation modeling. Transaction efficiency means time of transaction execution – T_{e-2-e} . In the case of sequentially transaction execution:

$$T_{e-2-e} = \sum_{i=1}^n T_i$$

where :

T_i – time of execution transaction on resource i

n – number of resources transaction sequentially use

As a starting point for simulation, the research on end-2-end transaction performance can be leveraged (ARMing transactions, HP OpenView Transaction Analyzer [11])

2. The part of IT infrastructure that services transactions includes resources of two types:
 - a. Servers, which serve transactions.
Transactions of different types have specified service time t_i on a server, where t – transaction type. Server is characterized by its state y_r , where r denotes the number of transactions in service. Each transaction on the server receives performance share $\mathbf{x}_i = \frac{\mathbf{x}_s}{r}, i \in 1..r$, where \mathbf{x}_s – constant which characterizes server performance. Thus service time for transaction i of type t if the resource is in state y_r will be $T_i = \mathbf{s}_t / \mathbf{x}_i$.
 - b. Interconnect which represents computer network.
The interconnect model is similar to server model. Transactions of different types have specified size \mathbf{s}_t , where t – transaction type. Interconnect is characterized by its state x_r , where r denotes the number of transactions in service. Each transaction receives bandwidth $\mathbf{x}_i = \frac{\mathbf{x}_I}{r}, i \in 1..r$, where \mathbf{x}_I – overall interconnect bandwidth. Thus service time for transaction i of type t if the resource is in state x_r will be $T_i = \mathbf{s}_t / \mathbf{x}_i$.
3. A transaction can generate other transactions and so on.
4. Each resource in IT infrastructure has a capacity and if the capacity of the resource is exhausted transactions put on the queue. If queue is full transaction(s) will be dropped.
5. Each transaction generates some amount of network traffic. If transaction requires execution on the server(s) network traffic may be generated twice or more (before execution on the server, during execution and after execution).

Using these assumptions we suggest the following algorithm of modeling IT infrastructure:

1. To analyze company IT infrastructure and formalize it in terms of developed building blocks.
2. Develop model based on the collected information about IT infrastructure and proposed assumptions
3. To do performance estimation of main IT infrastructure components (network, servers, printers etc) and adjust model parameters.
4. To perform simulation and check model results on the known set of input and output values.
5. “Play” with the model. (Optimize various model’s parameters, try what ifs etc.)

Such approach allows estimating IT company efficiency in rather convenient and cheap way. Simulation model is risk-free environment and any experiment can be done there without investment. Besides simulation model allows to estimate various strategies of company evolution, find the best one and as a result save money and reduce expenses.

IT Company Simulation Model Example

The first step of model development is to decide between many simulation languages, choose simulation environment to create and investigate model.

Simulation environments have different functionality and flexibility in comparison with traditional languages. It is evident that using of programming languages is unjustified

redundancy. Essential part of simulation tools is customized for specific application area: logistics, enterprise simulation, system dynamics etc and development of the model that does not match standard tool templates is often difficult. So scalability and flexibility of the tool are key points [5].

In response, we choose AnyLogic because of its unmatched flexibility and scalability. AnyLogic is a general-purpose simulation environment for discrete, continuous and hybrid systems. It employs UML-RT structure diagrams for building hierarchical object-oriented models way and hybrid statecharts for behavior specification. The generated model is Java and can be extended with user's Java code. The simulation engine handles discrete events and dynamically changing sets of algebraic-differential equations. It automatically detects "change" (or "state") events. Debugging and visualization facilities are present [6].

Model Description and Implementation

The goal of this executable model was to create plain and reasonable complete model example. This example should be proof of concept of IT Business simulation. Using developed objects users can construct in intuitive way more complex systems. Database integration allows customizing model including company's configuration and service level agreements.

Simulation model is used to study the dynamic behavior of IT Company, which provides IT services for customers. We consider two types of flows in IT Company – documents flows and transactions flows. Documents flows are result of business processes. While servicing customers and participating in internal processes departments create, send and receive documents. Transaction flows mean operations in IT infrastructure. Transactions of different types are generated by customers and serviced by company IT infrastructure.

The nature of document flows and the nature of transactions flows are essential different. IT infrastructure serves thousand of transactions per minute [2] [3], whereas document interchange takes place few times in hour. Conceptual decision is to separate IT Infrastructure as independent object and segregate flows of transactions and documents.

IT Company is a rather complex system and in order to simplify its modeling the system was divided into the following objects:

- Technical department. It traces operations fulfillment (availability, mean service time and etc.). Periodically this department informs Financial department with that statistics. Technical department requests funding for support expenses from Financial department.
- Financial department. It receives information about customer operations fulfillment from Technical department and uses this information to invoice customers for delivered service. If an SLA was violated penalties are calculated and paid to customers. Financial department sends support funding and salaries to others departments.
- Helpdesks. It receives problems from customers, resolve them and send replays back.
- IT Infrastructure. IT infrastructure is described below in section "IT Infrastructure".
- Customers. Customer cannot be modeled as a simple source of transaction. This substance should communicate with financial department paying invoices and overload charges. For more adequacy simulation customer interoperation with other departments was added (i.e. contacts with helpdesks in order to solve problems).

Structure of IT company simulation model is presented on the Figure 1.

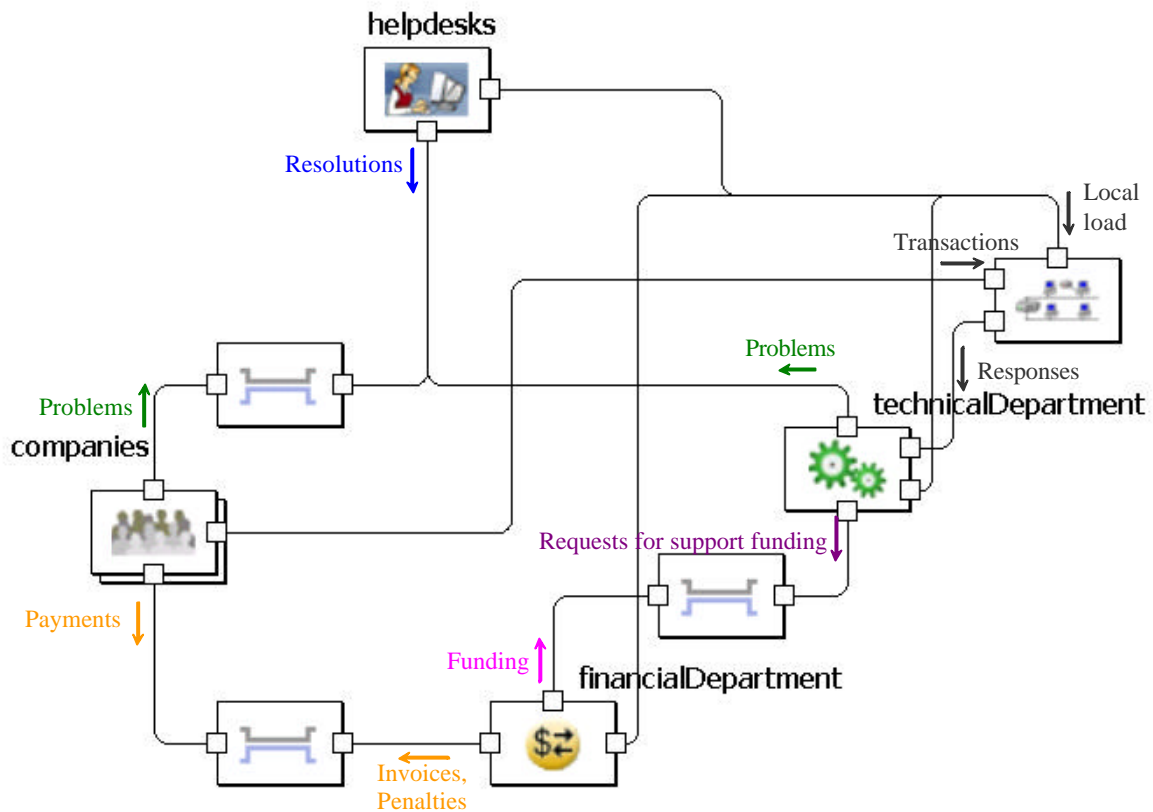

Figure 1: Model objects

Generally there are two tiers of objects: customers (companies) and various departments that form our company. Objects have behavior specified by statecharts or Java code. During simulation those objects exchange information by sending and receiving messages. Invoices, transactions, customer payments and etc are modeled as AnyLogic messages [7].

Modeling Document Flow

During simulation departments send, receive and treat documents in order to fulfill business processes of the company. General concepts of business processes modeling can be found in [8]. Documents types and typical scenarios of their exchange are the following:

- Invoice. It is a document that serves as a request for payment. Customers generate load composed from transactions. Company IT Infrastructure serves those transactions. Technical department trace operations fulfillment and periodically inform financial department with execution statistics. Using provided information as well as service level agreements financial department create and send invoices to customer. Service cost depends on number of total serviced transactions, penalties schema and etc. Payment mechanism is described in more detail in SLA agreements checking procedure.
- Customer payment. This document should be send by customer to financial department as a replay to invoice. Invoice contains full information about service cost and customer should pay for these services. Financial department receives customer payments and use that money for internal processes funding.
- Problems. Helpdesks provide technical support for customers. When customer detects problem it contacts helpdesk in order to resolve it. We model this interaction by Problem message. Customers send this message and wait for a response.

- Resolutions. This is a replay for Problem message. This message is generated by helpdesks after resolving customer problem.
- Funding requests. Nowadays infrastructure of even medium IT Company can be significant complex. Infrastructure contains a number of components each of them needs maintenance and support. A part of hardware failures demands manual actions (e.g. installation of new software provides better system usability and so on). Usually there is special department – technical department that is responsible for IT Infrastructure maintenance. Technical department requests support funding from financial department. We model such requests by the Funding request message.
- Salary requests. This document reflects internal financial flows – salaries. Departments periodically request Financial department for salaries. The amount of requested funding depends on department staff and hour people cost per hour.
- General payment. General payment is a document, which departments use to transfer funding and salaries.
- Operation information. Technical department traces transactions fulfillment. Service cost for individual customer depends on number of executed transactions. Department periodically informs financial department about transactions fulfillment status. Customers generate transactions of different types (E-Mail, Web access, database access and etc.). For each transaction type service level agreement is specified. That is why the technical department does not aggregate transactions and records statistics for each type. This document contains the following information:
 - Customer name
 - Transaction type
 - Total number of serviced transactions
 - Total number of dropped transactions
 - Mean service time

Modeling Transaction Flows

Infrastructure load is composed from customers' transactions and local load. We model each transaction by a single message. Message has the following properties: type of transaction and user identifier. Transactions arrive to IT Infrastructure and pass through the system. Local load arrives to special port and does not use interconnect (interconnect is a link between customers and infrastructure).

Modeling IT Infrastructure

It is very difficult or even impossible to create universal IT Infrastructure that will cover all range of possible configurations. Depending on a set of services which company provides IT Infrastructure will have different servers, interconnects and etc. We have analyzed a set of enterprises composed with departments, offices, headquarters etc. and most of them could be described in terms of reusable IT Infrastructure building blocks. General principles of networks design can be found in [1] and [9]. An example we are considering is presented in Figure 2.

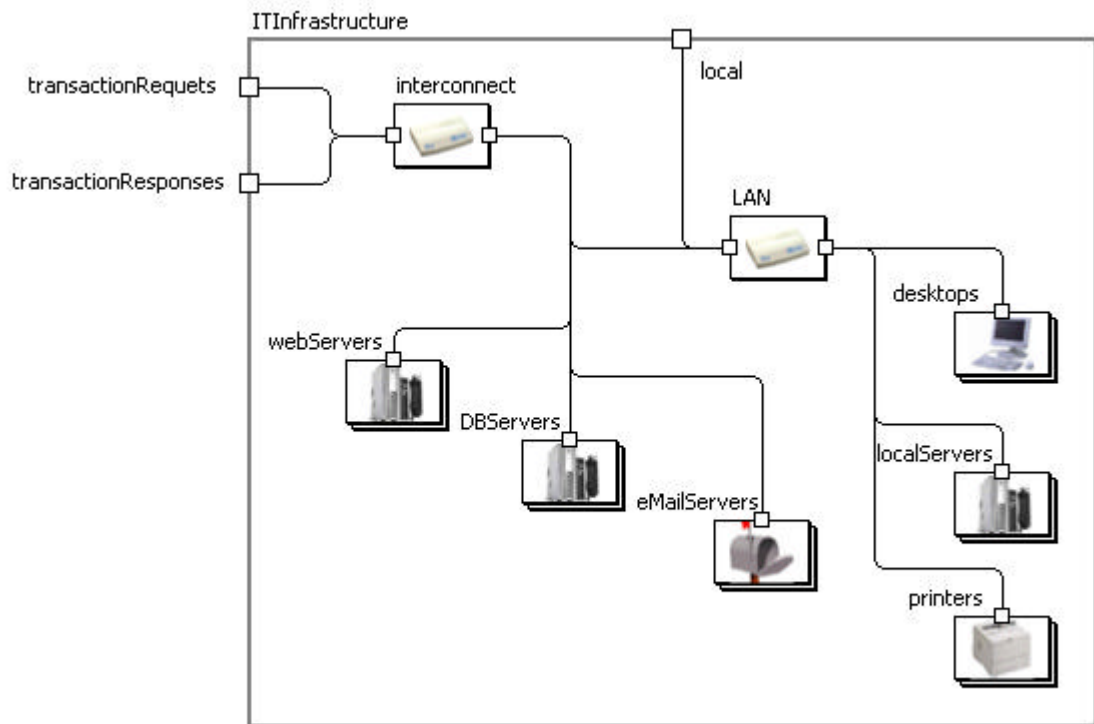

Figure 2: IT Infrastructure structure building blocks

IT Infrastructure includes the following elements:

- Interconnect. It connects customers and Infrastructure
- Servers. It represents e-mail, database and web servers
- LAN. It represents internal company network
- Local resources: local servers, printers and desktops. Departments generate load for these resources.

Transactions from customer arrive to “transactionRequests” port. Transactions that form local loading (applications, printers and local servers tasks) arrive to “local” port. Infrastructure serves transactions of the following types:

- Web requests (type 1). Transactions are generated on the customer side and serviced by cluster of web servers – “webServers”. 30 percents of those transactions generate transactions to Database server (type 2).
- Database server requests (type 2). Transactions are treated by DBServers.
- E-Mail transactions (type 3).
- Local load is formed from transactions generated by departments. Requests for desktop servicing (4), printers (5) or local servers (6) pass through LAN not using interconnect. 30 percents of desktop transactions generate requests to local servers and printers. 20 percent of local server transactions and 10 percent of printer transactions generate requests to desktop. In such way we model interactive work of user with local resources.

We suppose that resources are shared and have limited capacity. Performance of resource is shared between all transactions. So if transaction can be processed alone for time T it will be processed $N \cdot T$ time if there are N equal transactions being processed on CPU. When transaction message enters resource the service time for transaction is calculated. User should specify for certain transaction type the time of its execution.

SLA agreements checking procedure

Procedure of SLA checking is executed when financial department receives information about customer operations fulfillment from technical department. Service level agreements are available for different transactions types and contain the following parameters:

Parameter name	Description
Transaction type	1 - web access, 2 - database server access, 3 - e-mail, 4 - desktop load, 5 - local company servers
Priority	Priority for transaction of given SLA. If resource is overloaded and queue before it is in use transactions are fetched according priorities.
Requested loading	Number of transaction per hour for which SLA is applied.
Overload charges	Euro per percent of transactions, which exceed Requested loading. Those charges are paid by customer.
Availability	Desired percent of serviced transactions.
Availability tolerance	Tolerance in percents for availability.
Performance	Desired servicing speed (number of transactions per hour).
Performance tolerance	Tolerance for the performance requirements.
Revenue	Cost for one transaction.
Penalties availability	Euro per percent of transactions which exceed Availability. Those penalties are paid by our company.
Penalties performance	Penalties for performance violation.

Financial department search SLA for customer and check the parameters described below [10]:

- Requested loading. If customer has generated more transactions than it was agreed in the SLA, that customer should pay overload charge. For those transactions SLA is not checked. Total numbers of executed and dropped transactions will be proportional decreased.
- Availability. If a percent of dropped transactions exceeds a limit specified in SLA the following penalties will be calculated:

$$penalties = \frac{\Delta dropped \cdot penalties_availability}{total} \cdot 100\%$$

Δ dropped – number of dropped transactions exceeded SLA

penalties_availability – SLA parameter

total – number of total executed transactions

- Mean execution time. Similar to availability if the mean service time exceeds performance requirements the following penalties will be calculated:

$$penalties = \Delta performance \cdot penalties_performance$$

Δ performance – difference between real service time and SLA service time

penalties_performance – SLA parameter(euro)

Optimization of IT Company Model Parameters

Optimization is one of the primary goals of simulation modeling and can help solve problems where there are a) many ways of doing something; b) limited resources available. Optimization is widely used for solving various kinds of tasks but as to simulation it is usually used for decision-making. In the sections below we will consider two examples of optimization IT company model parameters in order to find the answer to the following questions:

- How many servers have to be installed in order to meet all service level agreements?
- What is the minimal transaction cost?

Optimizing Quantity of Servers

IT Infrastructure performance can be improved by adding new hardware resources – new servers, faster routers and etc. Deploying a new devices cause in growing support expenses. In example model we choose quantities of public servers (web, e-mail and database) as parameters of optimization. Objective is company balance because it is integral characteristic of company efficiency that includes support expenses:

$$B = I - \sum_{hours} E \rightarrow \max$$

$$E = \sum_i n_i \cdot s_i + E_0 + S$$

B - company balance

I - total company income

E - company expenses

n_i – quantity of public servers of type "i"

s_i – maintenance cost for server of type "i"

E_0 - support expenses of other IT Infrastructure devices

S - paid salaries

Optimizer tries to find optimal configuration to maximize balance, see Figure 3.

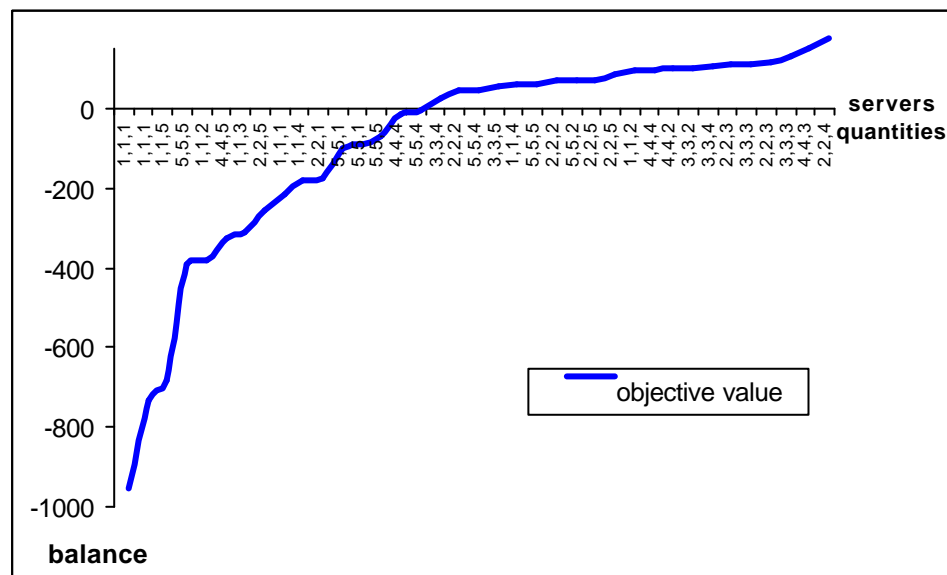

Figure 3: IT Infrastructure parameters optimization

Company balance is negative with the initial quantities of servers because of IT infrastructure performance is not enough and penalties for availability violation are significant. In result of optimization we found configuration (two web, two mail and four database servers), which maximize company balance with specified support expenses.

Optimizing Service Pricing

One of the task IT company can do using simulation modeling is breakeven analysis. The purpose of this analysis is finding the minimal prices, which will lead to zero balance.

Parameters of optimization are costs for transactions. Objective is square of company balance, the best value is zero - see Figure 4.

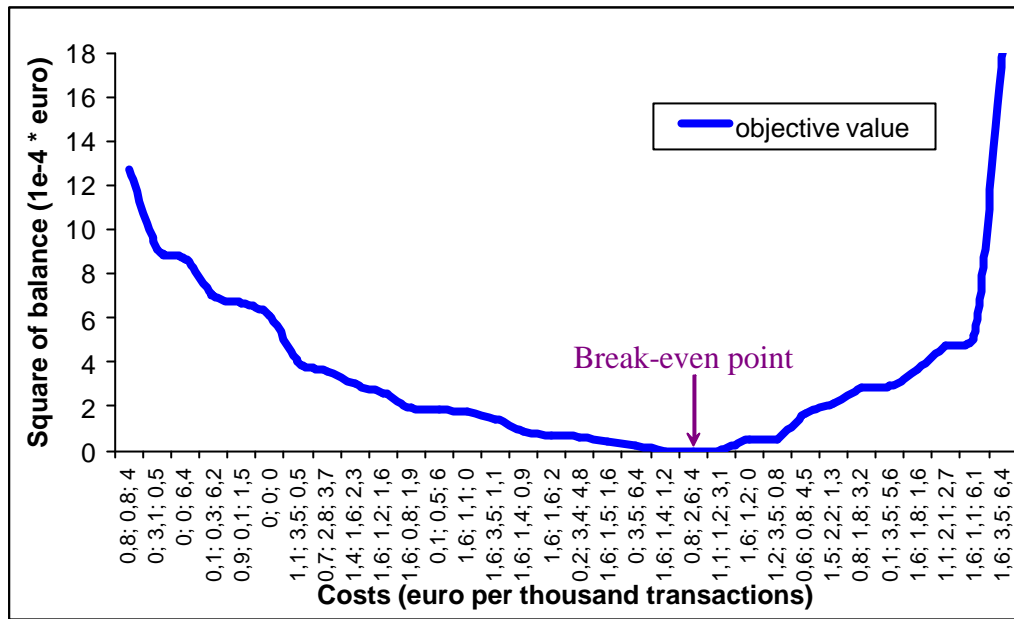

Figure 4: break-even analysis

Results of optimization are prices: 0.8€per thousand of web transactions, 2.6€per thousand of database transactions and 4€per thousand of e-mail transactions. This pricing schema results in zero balance for three month.

Conclusions

The model we built can serve as a proof of concept and demonstrate that simulation modeling may be successfully applied for estimating efficiency of IT companies as well as their IT infrastructures. Simulation modeling of IT company allows to do a lot of things including estimation various IT business strategies, optimize defined IT business parameter (such as service prices, infrastructure use, IT revenue, number of people etc.), estimate an impact of application regarding IT infrastructure management solutions (e.g. HP OpenView family products), evaluate IT infrastructure configuration options, calculate trending and choose the options of IT Infrastructure evolution and many other things. Actually the simulation model can serve as a decision support tool for an IT business and drive companies and their IT departments to both – agility and profit. Besides the implementation and usage costs of the models are very attractive in comparison to the potential benefits.

It is feasible to extend model with the possibility to simulate IT Management solution like HP OpenView in order to provide a prediction about efficiency of using such management solution for a particular company. Also we plan to evaluate adequacy of the model on the real system.

References

- [1] *White Papers, Hy-Performix Inc.* (<http://www.hyperformix.com/news/whitepapers.htm>)
- [2] *TPC-W: Benchmarking An Ecommerce Solution.* Wayne, D. Smith, Intel Corporation (http://www.tpc.org/tpcw/TPC-W_Wh.pdf)
- [3] *Top Ten TPC-W Results by Performance,* (http://www.tpc.org/tpcw/results/tpcw_perf_results.asp)
- [4] *HP Adaptive Enterprise Solutions Whitepapers.* Hewlett Packard (<http://www.hp.com>)
- [5] *Modeling Your Business to Manage Costs and Expectations.* G. Jeffrey Hoch (http://www.alchemymag.com/Web_First/ss.nsf/ArticleID/DDAS-4K2M3K/)
- [6] *AnyLogic User's Manual.* XJ Technologies Co (<http://www.xjtek.com>).
- [7] *AnyLogic Tutorial.* XJ Technologies Co (<http://www.xjtek.com>).
- [8] *DELIVERING RESULTS: EVOLVING BPR FROM ART TO ENGINEERING.* Richard J. Mayer, Paula S. deWitte (<http://www.idef.com/Downloads/pdf/bpr.pdf>)
- [9] *TOWARD A NETWORK DESIGN METHOD (IDEF14).* Richard J. Mayer, John W. Crump, Ronald Fernandes, Arthur Keen, Michael K. Painter
- [10] *How to Write and Manage Service Level Agreements for ATM Networks Part I: Background Guide for an SLA Template,* 1998 Visual Networks Inc., Telechoice Inc. (<http://www.teneo.co.uk/site/pdffiles/How%20to%20Write%20SLA%20-%20Part%201.pdf>)
- [11] *HP OpenView Transaction Analyzer 1.1. Product Brief.* (http://www.openview.hp.com/products/transaction_analyzer/pb/transact11_pb_feb03.pdf)